

RABEA®

Anterior Cervical Fusion

Dear Patient,

Changes to the spine due to wear or disease are often accompanied by pain that can greatly affect the quality of your life.

In this brochure we would like to tell you about a the treatment for persistent symptoms in the neck (cervical spine).

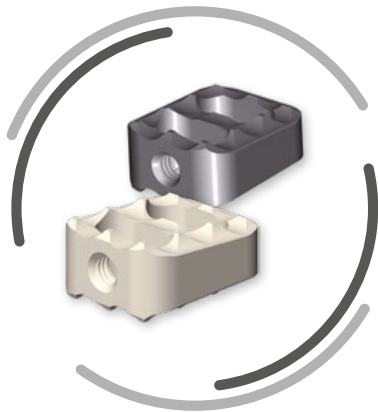

The Cervical Spine

The spine is an extraordinarily complex system of bones, cartilage, muscles and nerves, that has both static and dynamic functions. In addition it protects the spinal cord that lies within it as well as exiting nerves and vertebral arteries, that supply blood to the spinal cord, brain stem and cerebellum.

The cervical spine begins at the base of the skull (occiput) and consists of 7 small bones, called the cervical vertebrae: these (with the exception of the first two vertebrae) are joined firmly together by intervertebral discs. These discs consist of a firm ring enclosing a jelly-like core. The perfect interplay of the ring and core stabilises the cervical spine and, at the same time, allows a controlled range of movement between the vertebral bodies.

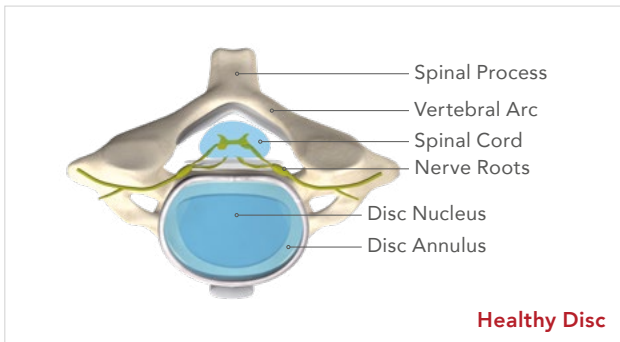

Healthy Disc

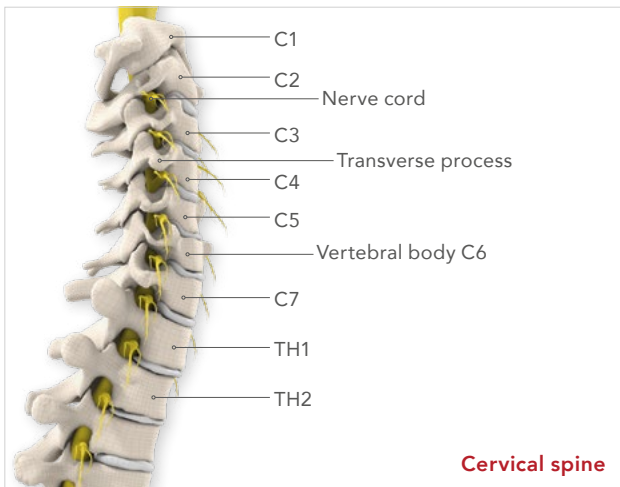

Cervical spine

Degeneration of the Disc

The spine is continually exposed to daily stresses and is also subject to natural ageing. This process, called degeneration, can start as early as your 20s and can result in bulging (prolapse) of the discs and bony changes (e.g. bony spurs) of the joints of the spine and the openings through which the nerves exit. This can, in turn, exert pressure on the neighbouring nerves or the spinal cord which can cause severe pains that often radiate through the shoulder and arm, and disturbances of sensation (numbness, oversensitivity, etc.).

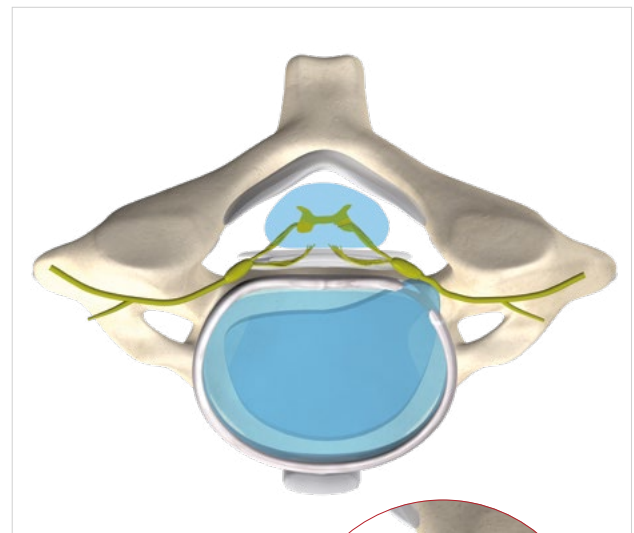

Herniated Disc

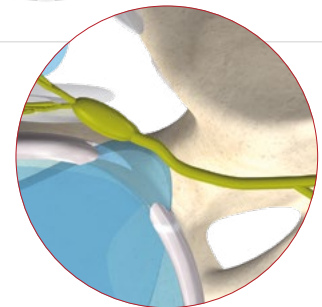

This brochure is intended to give you the important basic facts but it cannot replace individual advice from your doctor. Please ask your doctor for further questions in regard to your individual pathology indications. This and the implantation are the responsibility of the surgeon.

Fusion of the Cervical Spine

Often these symptoms can be treated by conservative methods (medicines, physiotherapy, etc.). However, if the symptoms are not resolved or adequately eased, then an operation may become necessary. This surgery involves removing the disc bulge and any bony spurs in order to relieve the pressure on the compressed nerves and the spinal cord. To ensure lasting relief, this section of the spine may be stiffened (fused). Your surgeon may use autologous bone or special implants to achieve this.

In some cases your surgeon might decide to also implant an additional fixating plate. This plate is placed in front of the cage and fixated in the adjacent vertebrae with two screws above and two screws underneath the treated disc.

The Operation with RABEA®

Your surgeon gains access to the spine through a small incision in the front of your neck. The wound might be spread open using a retractor system. Next, the diseased disc and other compressing structures such as bony spurs are removed in order to relieve nerves and the spinal cord. Then, the RABEA® implant is positioned into the available space and the wound is closed.

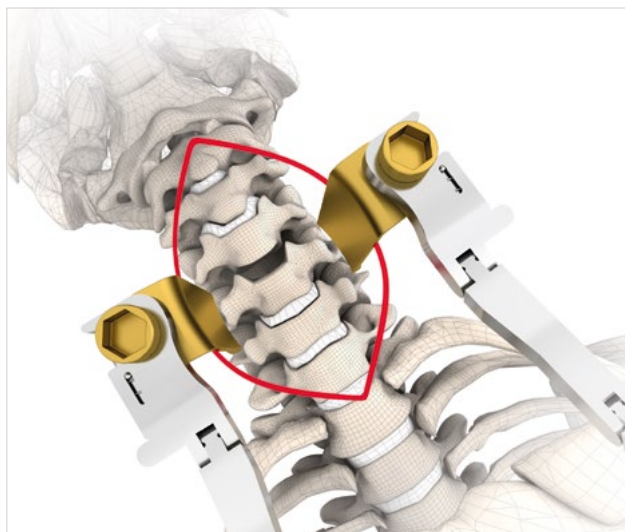

After the Operation

An operation on the cervical spine is generally not a major procedure and the RABEA® implant is immediately stable, so you can get out of bed on the day of the operation if you are feeling well. Nevertheless aftercare and follow-up examinations are determined by your treating physician to your individual requirements.

After the intervention, you will be allowed only very limited physical activity for an appropriate postoperative period. This applies in particular to the lifting of loads, rotating movements and any type of sport. Falls and sudden, jerky movements of the operated region must be avoided.

Your surgeon will give you more detailed information about what you can do after the operation and will also provide an individual plan for your aftercare (physiotherapy, mobilisation, muscle strengthening, etc.), so that you can quickly get back into your daily routine. Your doctor will also inform you if further follow-up examinations are necessary.

Please follow your doctor’s advice.

Implant Identification

You will find information to identify your implant as well as the name, address and website of SIGNUS on your implantation card, which will be given to you by your surgeon.

About RABEA®

RABEA® is a disc replacement implant for use in the cervical spine and is available as a high-performance medical polymer PEEK-OPTIMA® or titanium. It serves as temporary placeholder to restore disc height until firm bony fusion has taken place. They are not explanted again but remain in the patient. The implants are available in various designs, footprints and heights to enable adaption to different patient anatomies.

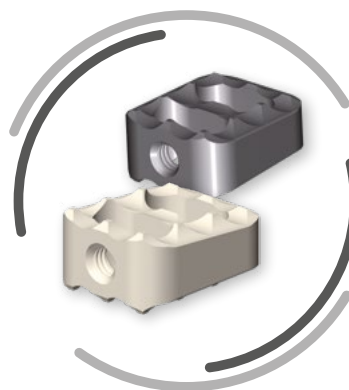

RABEA® Material

The implants are made from the following materials:
 Polyether ether ketone (PEEK-OPTIMA®) as per ASTM F2026
 Or

Titanium alloy (Ti-6Al-4V) as per ASTM F 136 / ISO 5832-3

X-ray markers:

Titanium alloy (Ti-6Al-4V) as per ASTM F 136 / ISO 5832-3

The materials are established materials for use as an implant. They are biocompatible, corrosion-resistant, non-toxic in the biological environment. Implants made of PEEK enable interference-free X-ray imaging.

RABEA® PEEK implants are conditionally MR safe. A patient with this implant can be safely scanned in an MRI system in accordance with the justification and the test methods in ASTM F2502. Testing of the effects due to forces, torque, heating or artefact formation was not carried out.

Non-clinical trials demonstrated that the RABEA® (titanium) implant is 'MRI conditional'. A patient with this implant can be safely examined in an MRI environment that complies with the following criteria:

- Static magnetic field strength of 3 T or less
- Maximum spatial magnetic field gradient of 720 Gauss/cm or less
- Maximum mean whole-body specific absorption rate (SAR) stated by the MRI system of 2.9 W/kg

Under these examination conditions a temperature increase in the implant of max. 1.7° C (1.5 T) can be expected during a continuous examination over 15 minutes.

In non-clinical trials the image distortion caused by the product extended to about 15 mm around the RABEA® titanium implant when using a gradient echo sequence and a 3 T MRI system.

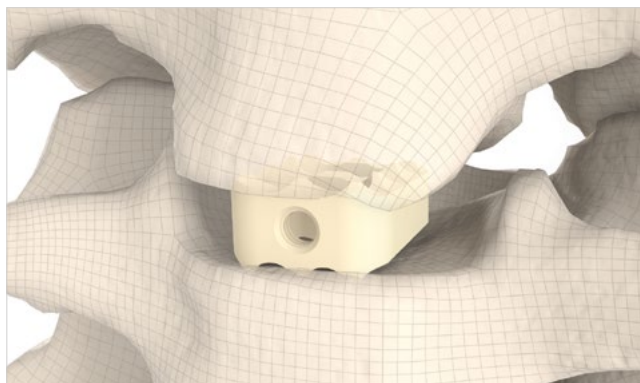

Undesirable Side Effects

Your doctor will inform you about general risks and possible complications of the spinal surgery.

The following are potential risks and complications related to the implant and which may necessitate repeat surgery:

- Loss of anchorage/fixation, subsidence or dislocation of the implant
- Pseudoarthrosis/absence of fusion
- Sensitivity to foreign bodies, allergic reactions or other local/systemic adverse reactions to the implant materials used
- Incorrect placement
- Vascular lesion
- Neural lesions with reversible or permanent neurological deficits or paralysis
- Infection
- Wear or breakage of implant components
- Pain or recurrent pain

When you should consult a Health Professional

If you experience one or more of the following, we recommend to contact your physician or any health professional:

- Worsening arm or leg pain
- Any new or worsening weakness in your arms or legs
- Any new pins and needles or numbness in your arms or legs
- Incontinence (bladder or bowel)
- A fever or a high temperature
- Redness, swelling or discharge from the wound
- Increasing neck pain
- Difficulties swallowing
- Problems with breathing

If you experience any serious incident in relation to RABEA®, please report to the manufacturer SIGNUS Medizintechnik GmbH (qm@signus.com).

If you are resident in Australia, please also report to the Therapeutic Goods Administration (<https://www.tga.gov.au/reporting-problems>).

Important information: Please keep in mind that SIGNUS Medizintechnik GmbH just provides general information about the treatment. Specific questions can only be answered by your doctor. SIGNUS assumes no liability for wrong indication or medical malpractice.